

PCI express 3.0 x1 Jumper Cable

Brand name: ADT-LINK

Product name: PCIe x1 jumpers cable

Product model: R11SS, R11FF, R11LR, R11NS, R11NF, R11NL, R11NR

Transferspeed:PCIe 3.0 x1 full speed, 8G/bps (Max.)

Wire length: 3 ~ 100 cm, the length can be customized,

Application: PCIe x1 board to board jumpers , extender , adapter , flexible , foldable , pluggable

Operating Temp: -20 ~ 80°C

RoHS Compliant: Yes

If your applications uses a mother board that needs to link to another PCB via PCIe, and that PCB has PCIe connectors instead of edge fingers, then the PCIe Jumper Assemblies may fit your need. All of the speed and flexibility of the original ADT Extender Assemblies, but for card-to-card applications.

Restrictions on use: Only specified by professional engineers to purchase, general use cannot be used, ordinary buyers should not buy.

ADT PCIe Jumper products Part-Number Description:

Part-Number	Description	Bandwidth
R11SS	PCI-E x1 ,goldfinger to goldfinger, Tx to Tx direct extension	PCIe 3.0 x1 (8G/bps)
R11FF	PCI-E x1 ,connector to connector, Tx to Txdirect extension	PCIe 3.0 x1 (8G/bps)
R11LR	PCI-E x1 ,connector to connector, Tx to Txdirect extension	PCIe 3.0 x1 (8G/bps)
R11NS	PCI-E x1 ,goldfingerto goldfinger, Tx to Rx signal swap	PCIe 3.0 x1 (8G/bps)
R11NF	PCI-E x1 ,goldfingerto connector, Tx to Rx signal swap	PCIe 3.0 x1 (8G/bps)
R11NL	PCI-E x1 ,goldfingerto connector, Tx to Rx signal swap	PCIe 3.0 x1 (8G/bps)
R11NR	PCI-E x1 ,goldfingerto connector, Tx to Rx signal swap	PCIe 3.0 x1 (8G/bps)

Cable length Description:

The length of the wire refers to the part of the visible wire. It does not include the PCB and the connector. For the wire length, please refer to the 8cm arrow in the figure below.

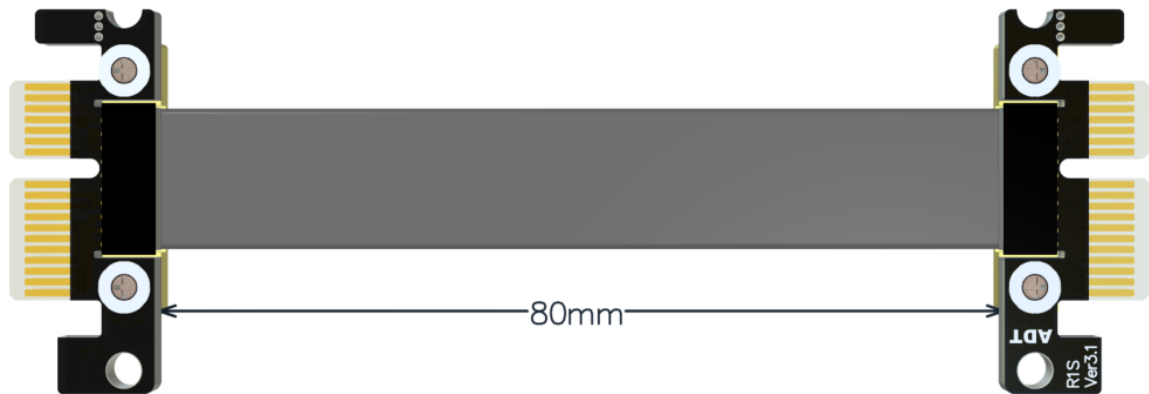

Q&A:

Is there any EMI shielding for Cable?

The extender utilizes the latest materials for EMI shielding with five sole flat cables design. This technique allows each cable to be fully covered by electromagnetic interference shielding with conducting polymer to guard against incoming or outgoing emissions of electromagnetic frequencies, minimize disturbance and degradation on performance, and reduce the weight of the extender.

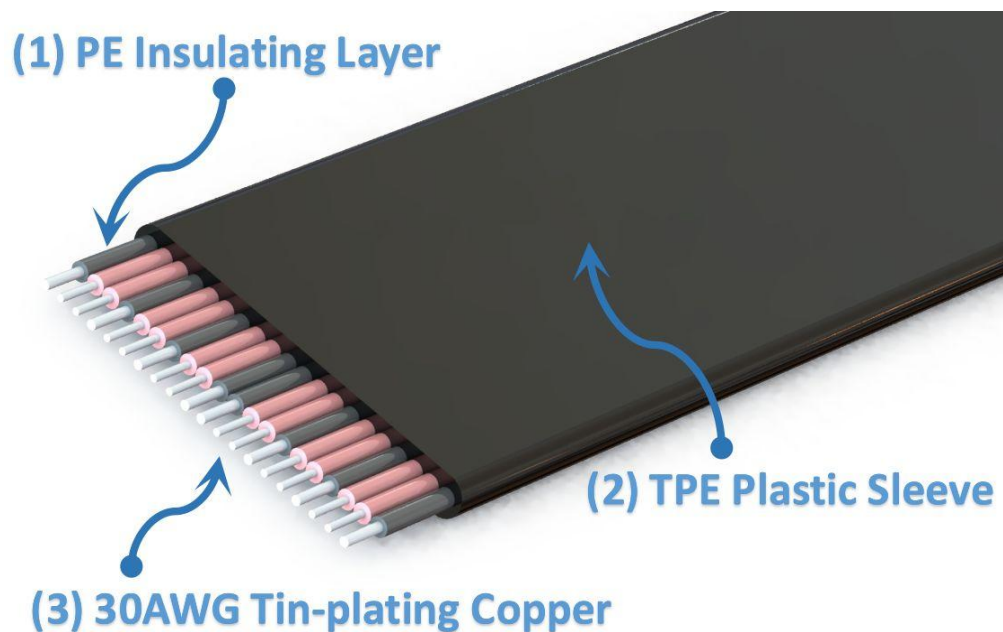

Cable thickness? Can it be bent?

The thickness of the wire is 1.4mm, and it can be bent and folded without affecting the use.



Is there a PCIe Tx-Rx signal exchange?

The PCI express signal trace of this product refers to the following picture.

Model R11SS signal extension function, PCIe signal direct connection has no conversion, Tx to Tx, Rx to Rx, suitable for Jump, Extension use.

Model R11NS differential signals are exchanged, PCIe differential signals Tx to Rx, Rx to Tx, suitable for Master-Slave applications.

P/N: R11SS

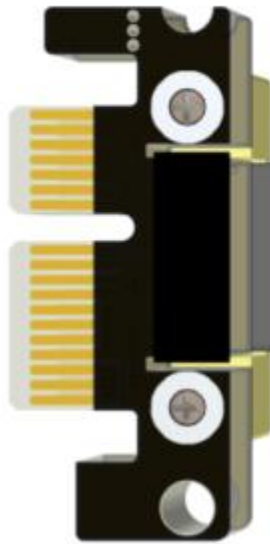

PCIe Tx > PCIe Tx

PCIe Rx < PCIe Rx

P/N: R11NS

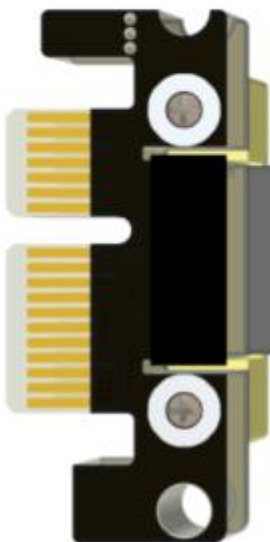

PCIe Tx > PCIe Rx

PCIe Rx < PCIe Tx

Photo:

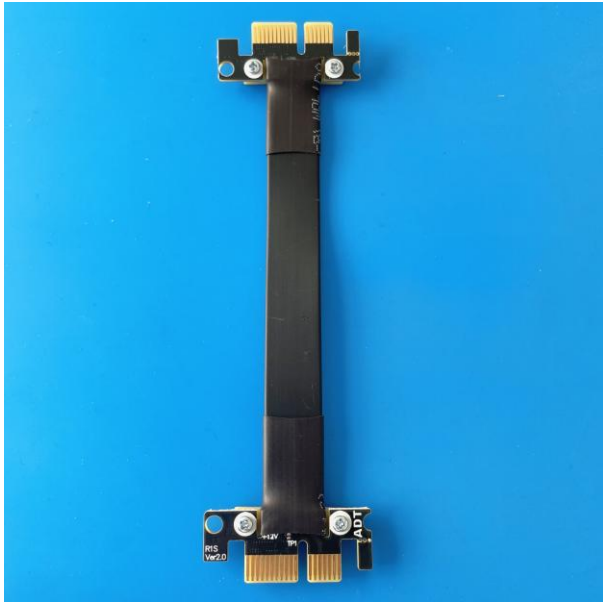
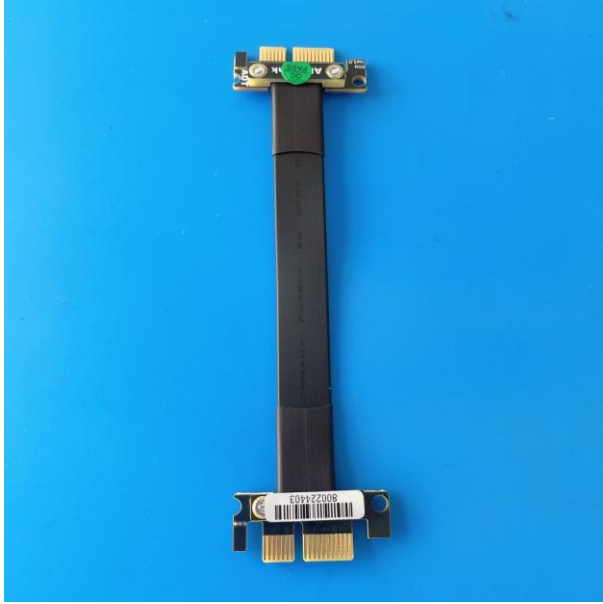

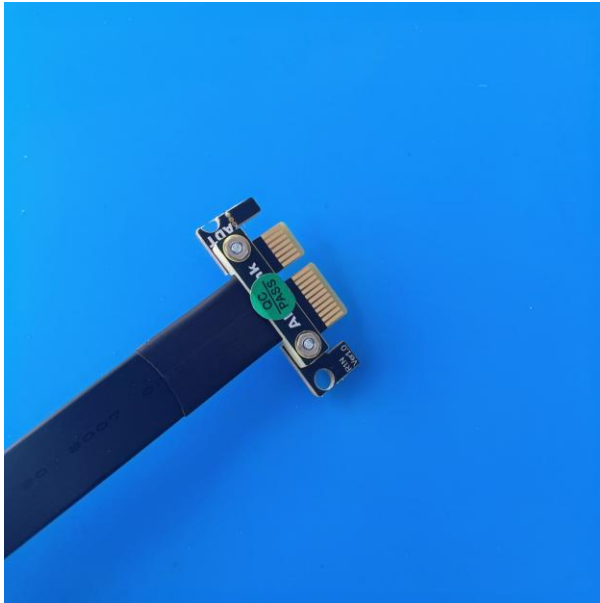

Download:

To open 3D PDF files. Please use [Adobe Reader DC](#) software.

FTP: Los Angeles

3D PDF files download http://www.adt.link/Uploads/download/ADT_R11_Jump_3D.zip

3D STEP files download http://www.adt.link/Uploads/download/ADT_R11_Jump_STEP.zip

Schematic files download http://www.adt.link/Uploads/download/ADT_R11_Schematic.zip

FTP: Hong Kong

3D PDF files download http://www.adtlink.cn/Uploads/download/ADT_R11_Jump_3D.zip

3D STEP files download http://www.adtlink.cn/Uploads/download/ADT_R11_Jump_STEP.zip

Schematic files download http://www.adtlink.cn/Uploads/download/ADT_R11_Schematic.zip

WebShop:

http://www.adt.link/product/R11_Jump-Shop.html

Restrictions on use: Only specified by professional engineers to purchase, general use cannot be used, ordinary buyers should not buy.

PREVIOUS : R44SFNEXT : R11SF-WK